

DATA SHEET

MKP 338 6 Y2
**Interference suppression film
capacitors**

Product specification
New
File under BCcomponents, BC05

2001 Jun 22

Interference suppression film capacitors MKP 338 6 Y2

MKP RADIAL POTTED TYPE

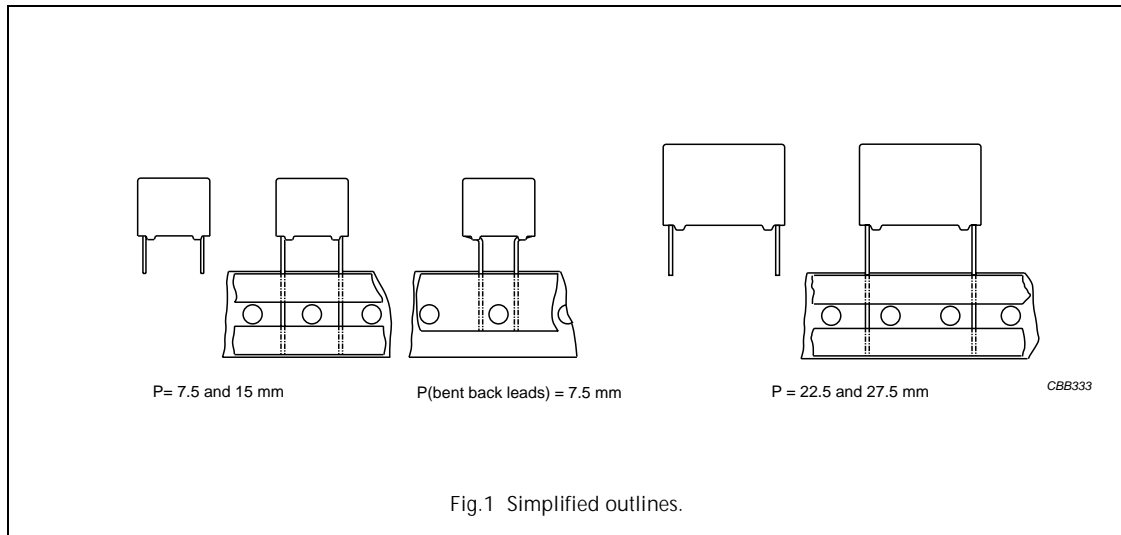
 PITCH 7.5/15/22.5/27.5 mm
 PITCH 7.5 mm (bent back lead)

FEATURES

- 7.5 to 27.5 mm lead pitch
- Supplied loose in box, taped on ammpack or reel
- Consists of a low-inductive wound cell of metallized polypropylene film, potted in a flame-retardant case.

APPLICATIONS

- For Y2-electromagnetic interference suppression
- Specially designed to meet the requirements of the "IEC 60384-14 2nd edition, EN 132400", requiring for Y2 a 5 kV peak pulse voltage test and both the UL1414 and CSA-C22.2 No. 1 specification.

DETAIL SPECIFICATION

For more detailed data and test requirements see "Type detail specification HQN-384-14/121".



QUICK REFERENCE DATA⁽¹⁾

DESCRIPTION	VALUE
Capacitance range (E12 series)	1 to 470 nF
Capacitance tolerance	±20%; ±10%; ±5%
Rated (AC) voltage , 50 to 60 Hz	300 V
Rated (DC) voltage	1000 V
Climatic category	55/105/56/B
Rated temperature	105 °C
Maximum application temperature	105 °C
Reference specifications	IEC 60384-14 2nd edition and EN 132400
Safety approvals:	
250 V	UL1414; note 2
300 V	UL1283; ENEC; note 2
Materials	qualified in accordance with UL94V-O
Safety class	Y2; line bypass and antenna coupling

Notes

1. Under development.
2. Pending.

Interference suppression film capacitors**MKP 338 6 Y2****SAFETY APPROVALS AND SAFETY TEST REPORT****Approvals**

SAFETY APPROVALS (X2)		VOLTAGE	VALUE	FILE NUMBERS
	UL1414 and CSA-C22.2 No.1	250 V (AC)	1 nF to 470 nF	pending
	UL1283 and CSA-C22.2 No.8	300 V (AC)	1 nF to 470 nF	pending
	ENEC (EN132400)	300 V (AC)	1 nF to 470 nF	pending

Safety test report

SAFETY TEST REPORT	VOLTAGE	VALUE	FILE NUMBERS
CB TEST CERTIFICATE	300 V (AC)	1 nF to 470 nF	pending

The Enec-approval together with the CB-Certificate replace all national approval marks of the following countries (they have already signed the ENEC-Agreement): Austria; Belgium; Czech. Republic; Denmark; Finland; France; Germany; Greece; Hungary; Ireland; Italy; Luxembourg; Netherlands; Norway, Portugal; Slovenian; Spain; Sweden; Switzerland and United Kingdom.

Interference suppression film capacitors

MKP 338 6 Y2

COMPOSITION OF CATALOGUE NUMBER

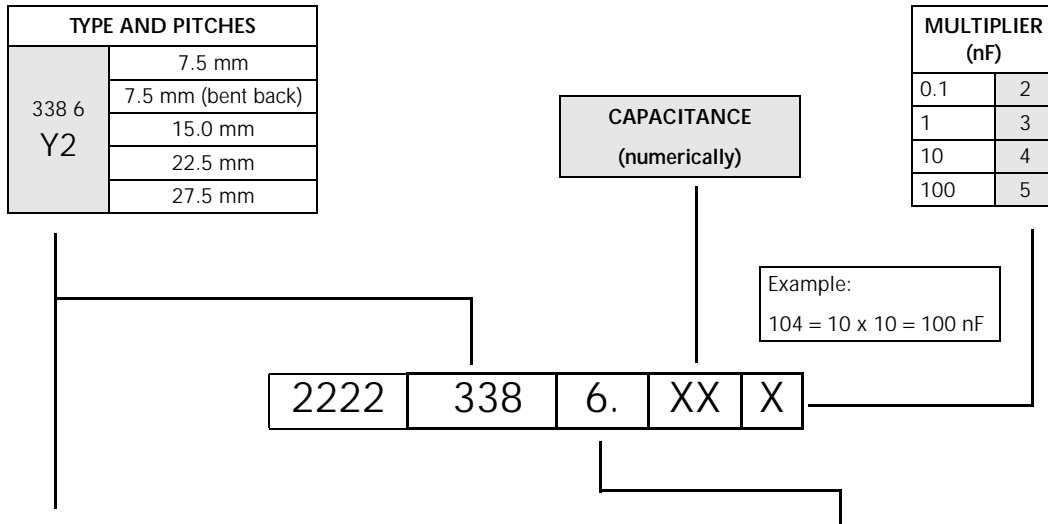

TYPE	PACKAGING	STANDARD DIMENSIONS	C-TOL	PREFERRED TYPES
338 6 Y2	loose in box	lead length 3.5 mm	±20%	60
		lead length 5.0 mm		62
		lead length 25.0 mm		64
	taped	pitch 7.5 mm or bent back to 7.5 mm		66
ALTERNATIVE PITCH SIZES				ON REQUEST
338 6 Y2	loose in box	lead length 3.5 mm	±20%	6.
		lead length 5.0 mm		6.
		lead length 25.0 mm		6.
ALTERNATIVE TAPED VERSION				ON REQUEST
338 6 Y2	taped		±20%	6.
ALTERNATIVE C-TOL				ON REQUEST
338 6 Y2	loose in box	lead length 3.5 mm	±10%	61
			±5%	6.
		lead length 5.0 mm	±10%	63
			±5%	6.
		lead length 25.0 mm	±10%	65
			±5%	6.
	taped	pitch 7.5 mm or bent back to 7.5 mm	±10%	67
			±5%	6.
		±10%	6.	
		±5%	6.	

Interference suppression film capacitors

MKP 338 6 Y2

MKP 338 6 GENERAL DATA

PITCH 7.5 mm

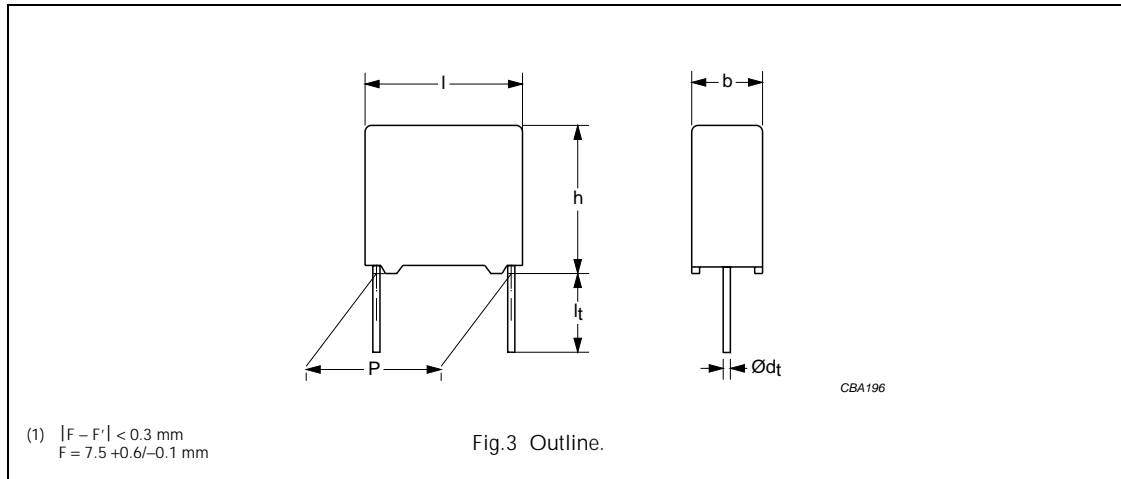

Specific reference data for the 300 V AC (Y2) capacitors

DESCRIPTION	VALUE		
	at 1 kHz	at 10 kHz	at 100 kHz
Tangent of loss angle: $C \leq 470 \text{ nF}$	$\leq 10 \times 10^{-4}$	$\leq 20 \times 10^{-4}$	$\leq 100 \times 10^{-4}$
Rated voltage pulse slope (dU/dt)R at 420 V	100 V/ μs		
R between leads, for $C \leq 0.33 \mu\text{F}$ at 100 V; 1 minute	$>15000 \text{ M}\Omega$		
R between leads and case; 100 V; 1 minute	$>30000 \text{ M}\Omega$		
Withstanding (DC)voltage (cut off current 10 mA); rise time 100 V/s:	3400 V; 1 minute		
Withstanding (AC) voltage between leads and case	2100 V; 1 minute		

Available 300 V (AC) Y2 versions

PACKAGING	DIMENSIONS	C-tol	FIRST 9 DIGITS OF CATALOGUE NUMBER	ORDERING
Loose in box	$l_t = 3.5 +1/-0.5 \text{ mm}$	$\pm 20\%$	2222 338 60...	preferred
		$\pm 10\%$	2222 338 61...; note 1	on request
		$\pm 5\%$	2222 338 6...; note 1	on request
	$l_t = 5.0 \pm 1.0 \text{ mm}$	$\pm 20\%$	2222 338 62...	preferred
		$\pm 10\%$	2222 338 63...; note 1	on request
		$\pm 5\%$	2222 338 6...; note 1	on request
	$l_t = 25.0 \pm 2.0 \text{ mm}$	$\pm 20\%$	2222 338 64...	preferred
		$\pm 10\%$	2222 338 65...; note 1	on request
		$\pm 5\%$	2222 338 6...; note 1	on request
Ammopack	$H = 18.5 \text{ mm}$; for $P_0 = 12.7 \text{ mm}$	$\pm 20\%$	2222 338 66...	preferred
		$\pm 10\%$	2222 338 6...; note 1	on request
		$\pm 5\%$	2222 338 6...; note 1	on request

Note

- Other dimensions for $\pm 10\%$ and $\pm 5\%$ tolerance values.

Interference suppression film capacitors

MKP 338 6 Y2

 $U_{Rac} = 300 \text{ V (Y2)}$; $U_{Rdc} = 1000 \text{ V}$

loose and taped

C ⁽¹⁾ (μF)	DIMENSIONS b × h × l (mm)	MASS (g)	CATALOGUE NUMBER				
			LOOSE IN BOX			AMMOPACK	
			short leads		long leads		H = 18.5 mm; P ₀ = 12.7 mm
			$l_t = 3.5+1/-0.5 \text{ mm}$	$l_t = 5.0 \pm 1.0 \text{ mm}$	$l_t = 25.0 \pm 2.0 \text{ mm}$		
			C-tol = $\pm 20\%$				C-tol = $\pm 20\%$
catalogue number		last 5 digits		last 5 digits			
Pitch = $7.5 \pm 0.4 \text{ mm}$; $d_t = 0.50 \pm 0.05 \text{ mm}$							
0.001	4.0 × 9.0 × 10.0	0.5	2222 338 60102	.. 62102	.. 64102	.. 66102	
0.0012			2222 338 60122	.. 62122	.. 64122	.. 66122	
0.0015			2222 338 60152	.. 62152	.. 64152	.. 66152	
0.0018			2222 338 60182	.. 62182	.. 64182	.. 66182	
0.0022			2222 338 60222	.. 62222	.. 64222	.. 66222	
0.0027			2222 338 60272	.. 62272	.. 64272	.. 66272	
0.0033	5.0 × 10.5 × 10.0	0.9	2222 338 60332	.. 62332	.. 64332	.. 66332	
0.0039			2222 338 60392	.. 62392	.. 64392	.. 66392	
0.0047	6.0 × 11.5 × 10.0	1.0	2222 338 60472	.. 62472	.. 64472	.. 66472	
0.0056			2222 338 60562	.. 62562	.. 64562	.. 66562	

Note

- Under development.

Interference suppression film capacitors

MKP 338 6 Y2

MKP 338 6 GENERAL DATA

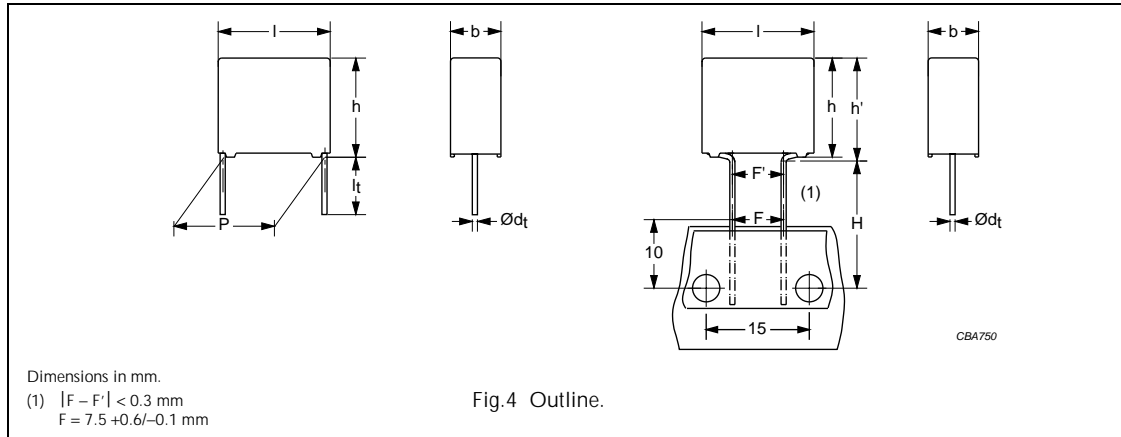
PITCH 7.5/15/22.5/27.5 mm
PITCH 7.5 mm (bent back leads)

Specific reference data for the 300 V AC (Y2) capacitors

DESCRIPTION	VALUE		
	at 1 kHz	at 10 kHz	at 100 kHz
Tangent of loss angle: $C \leq 470 \text{ nF}$	$\leq 10 \times 10^{-4}$	$\leq 20 \times 10^{-4}$	$\leq 100 \times 10^{-4}$
Rated voltage pulse slope (dU/dt)R at 615 V	100 V/ μs		
R between leads, for $C \leq 0.33 \mu\text{F}$ at 100 V; 1 minute	$>15000 \text{ M}\Omega$		
RC between leads, for $C > 0.33 \mu\text{F}$ at 100 V; 1 minute	$>5000 \text{ s}$		
R between leads and case; 100 V; 1 minute	$>30000 \text{ M}\Omega$		
Withstanding (DC) voltage (cut off current 10 mA); rise time 100 V/s:	3400 V; 1 minute		
Withstanding (AC) voltage between leads and case	2100 V; 1 minute		

Available 300 V (AC) Y2 versions

PACKAGING ⁽¹⁾	DIMENSIONS	C-tol	FIRST 9 DIGITS OF CATALOGUE NUMBER	ORDERING
Loose in box	$l_t = 3.5 \pm 0.3 \text{ mm}$	$\pm 20\%$	2222 338 60...	preferred
		$\pm 10\%$	2222 338 61...; note 2	on request
		$\pm 5\%$	2222 338 6...; note 2	on request
	$l_t = 5.0 \pm 1.0 \text{ mm}$	$\pm 20\%$	2222 338 62...	preferred
		$\pm 10\%$	2222 338 63...; note 2	on request
		$\pm 5\%$	2222 338 6...; note 2	on request
	$l_t = 25.0 \pm 2.0 \text{ mm}$	$\pm 20\%$	2222 338 64...	preferred
		$\pm 10\%$	2222 338 65...; note 2	on request
		$\pm 5\%$	2222 338 6...; note 2	on request
Taped on reel; bent back	$H = 16.0 \text{ mm}$; for $P_0 = 15.0 \text{ mm}$	$\pm 20\%$	2222 338 66...	preferred
		$\pm 10\%$	2222 338 67...; note 2	on request
		$\pm 5\%$	2222 338 6...; note 2	on request
Taped on reel	$H = 18.5 \text{ mm}$; for $P_0 = 12.7 \text{ mm}$	$\pm 20\%$	2222 338 6...	on request
		$\pm 10\%$	2222 338 6...; note 2	on request
		$\pm 5\%$	2222 338 6...; note 2	on request

Notes

1. Taped on reel pitch = 27.5 mm is not available.
2. Other dimensions for $\pm 10\%$ and $\pm 5\%$ tolerance values.

Interference suppression film capacitors

MKP 338 6 Y2

 $U_{Rac} = 300\text{ V (Y2)}$; $U_{Rdc} = 1000\text{ V}$

loose and taped

C ⁽¹⁾ (μF)	DIMENSIONS ⁽²⁾ b × h (h') × l (mm)	MASS (g)	CATALOGUE NUMBER				
			LOOSE IN BOX			REEL	
			short leads		long leads		H = 16.0 mm; P ₀ = 15.0 mm
			l _t = 3.5 ±0.3 mm	l _t = 5.0 ±1.0mm	l _t = 25.0 ±2.0mm		
			C-tol = ±20%				C-tol = ±20%
catalogue number		last 5 digits		last 5 digits			
Pitch = 15.0 ±0.4 mm; d _t = 0.60 ±0.06 mm					pitch = 7.5 mm (bent back)		
0.0068	5.0 × 11.0 (12.0) × 17.5	1.2	2222 338 60682	.. 62682	.. 64682	.. 66682	
0.0082			2222 338 60822	.. 62822	.. 64822	.. 66822	
0.01			2222 338 60103	.. 62103	.. 64103	.. 66103	
0.012			2222 338 60123	.. 62123	.. 64123	.. 66123	
0.015	6.0 × 12.0 (14.0) × 17.5	1.4	2222 338 60153	.. 62153	.. 64153	.. 66153	
0.018			2222 338 60183	.. 62183	.. 64183	.. 66183	
Pitch = 15.0 ±0.4 mm; d _t = 0.80 ±0.08 mm					pitch = 7.5 mm (bent back)		
0.022	7.0 × 13.5 (15.0) × 17.5	1.9	2222 338 60223	.. 62223	.. 64223	.. 66223	
0.027			2222 338 60273	.. 62273	.. 64273	.. 66273	
0.033	8.5 × 15.0 (17.0) × 17.5	2.6	2222 338 60333	.. 62333	.. 64333	.. 66333	
0.039			2222 338 60393	.. 62393	.. 64393	.. 66393	
0.047	10.0 × 16.5 (18.5) × 17.5	3.1	2222 338 60473	.. 62473	.. 64473	.. 66473	
0.056			2222 338 60563	.. 62563	.. 64563	.. 66563	
Pitch = 22.5 ±0.4 mm; d _t = 0.80 ±0.08 mm					pitch = 7.5 mm (bent back)		
0.068	8.5 × 18.0 × 26.0	4.4	2222 338 60683	.. 62683	.. 64683	not available	
0.082			2222 338 60823	.. 62823	.. 64823		
0.1	10.0 × 19.5 × 26.0	5.5	2222 338 60104	.. 62104	.. 64104		
0.12	12.0 × 22.0 × 26.0	7.8	2222 338 60124	.. 62124	.. 64124		
0.15			2222 338 60154	.. 62154	.. 64154		
Pitch = 27.5 ±0.4 mm; d _t = 0.80 ±0.08 mm					pitch = 7.5 mm (bent back)		
0.18	11.0 × 21.0 × 31.0	7.8	2222 338 60184	.. 62184	.. 64184	not available	
0.22	13.0 × 23.0 × 31.0	10.4	2222 338 60224	.. 62224	.. 64224		
0.27	15.0 × 25.0 × 31.0	12.8	2222 338 60274	.. 62274	.. 64274		
0.33	18.0 × 28.0 × 31.0	17.2	2222 338 60334	.. 62334	.. 64334		
0.39			2222 338 60394	.. 62394	.. 64394		
0.47	18.0 × 28.0 × 31.0	20.4	2222 338 60474	.. 62474	.. 64474		

Notes

- Under development.
- Dimensions in brackets for bent back leads.

Interference suppression film capacitors

MKP 338 6 Y2

CONSTRUCTION

Description

- Low-inductive wound cell of metallized polypropylene (PP) film, potted with epoxy resin in a flame-retardant case
- Radial leads, solder-coated
- Small stand-off pips allow removal of solder flux etc. during cleaning of the printed-circuit board.

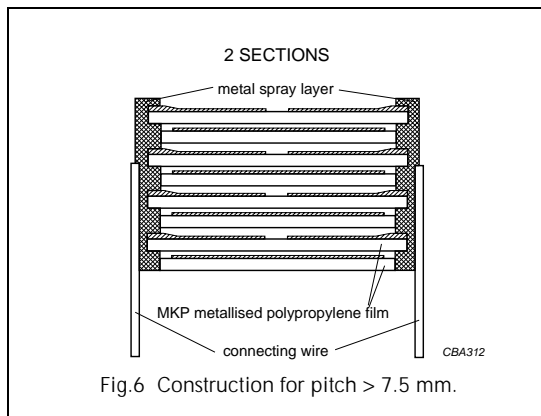
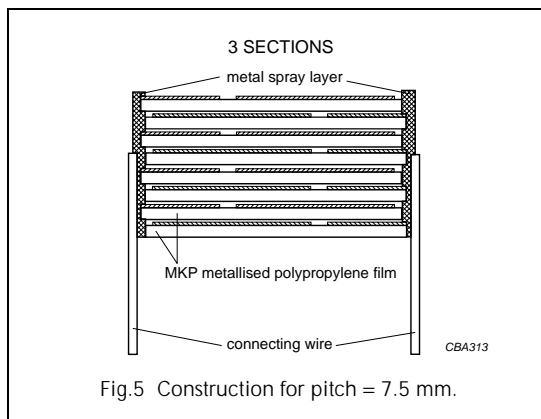

Mounting

NORMAL USE

The capacitors are designed for mounting on printed-circuit boards. The capacitors packed in bandoliers are designed for mounting on printed-circuit boards by means of automatic insertion machines.

For detailed tape specifications refer to this handbook, chapter "Packaging information".

SPECIFIC METHOD OF MOUNTING TO WITHSTAND VIBRATION AND SHOCK

In order to withstand vibration and shock tests, it must be ensured that the stand-off pips are in good contact with the printed-circuit board:

- For pitches ≤ 15 mm capacitors shall be mechanically fixed by the leads.
- For larger pitches the capacitors shall be mounted in the same way and the body clamped.

SPACE REQUIREMENTS ON PRINTED-CIRCUIT BOARD

The maximum length and width of film capacitors is shown in Fig.7:

- Eccentricity as in Fig.7. The maximum eccentricity is smaller than or equal to the lead diameter of the product concerned.
- Product height with seating plane as given by "IEC 60717" as reference: $h_{\max} \leq h + 0.3$ mm or $h_{\max} \leq h' + 0.3$ mm.

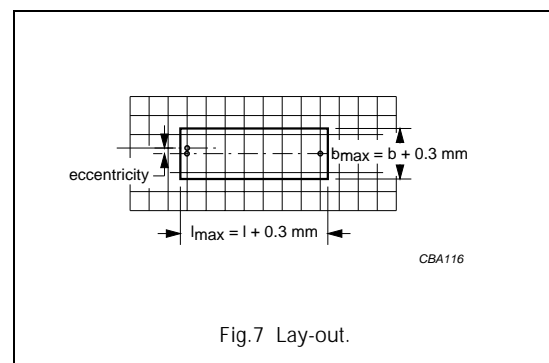

Storage temperature

- Storage temperature: $T_{\text{stg}} = -25$ to $+40$ °C with RH maximum 80% without condensation.

RATINGS AND CHARACTERISTICS REFERENCE CONDITIONS

Unless otherwise specified, all electrical values apply to an ambient temperature of 23 ± 1 °C, an atmospheric pressure of 86 to 106 kPa and a relative humidity of $50 \pm 2\%$.

For reference testing, a conditioning period shall be applied over 96 ± 4 hours by heating the products in a circulating air oven at the rated temperature and a relative humidity not exceeding 20%.

Interference suppression film capacitors

MKP 338 6 Y2

CHARACTERISTICS

Capacitance

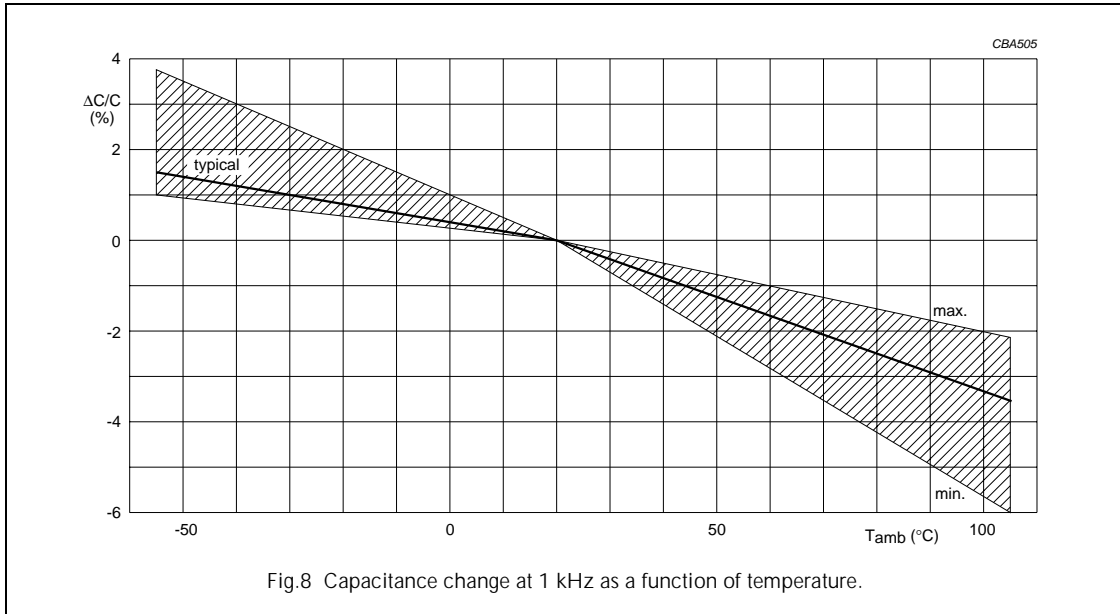

Tangent of loss angle

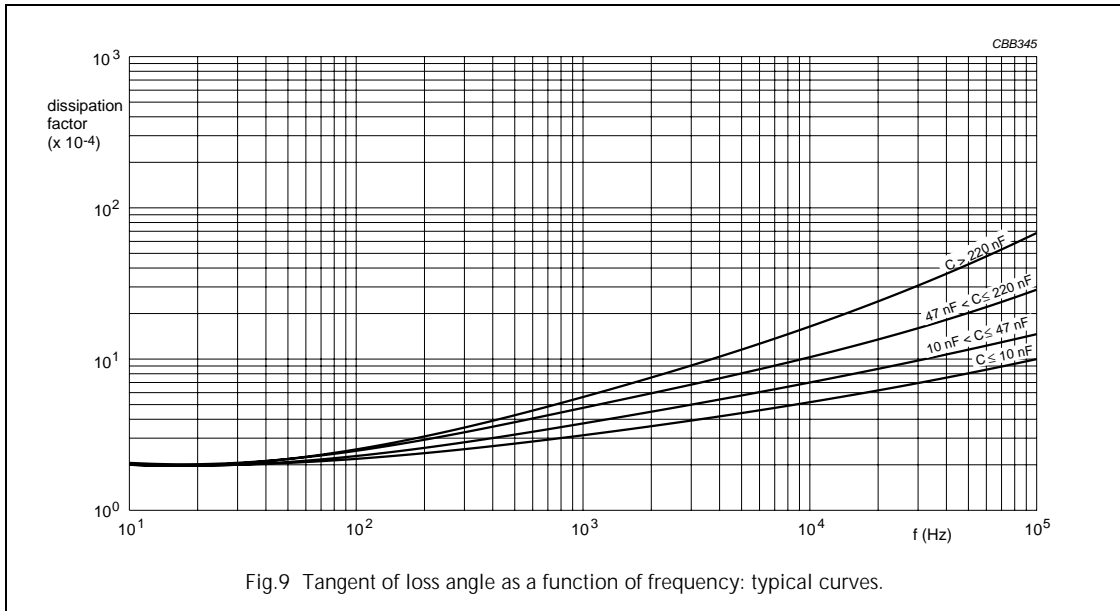

Interference suppression film capacitors

MKP 338 6 Y2

Impedance

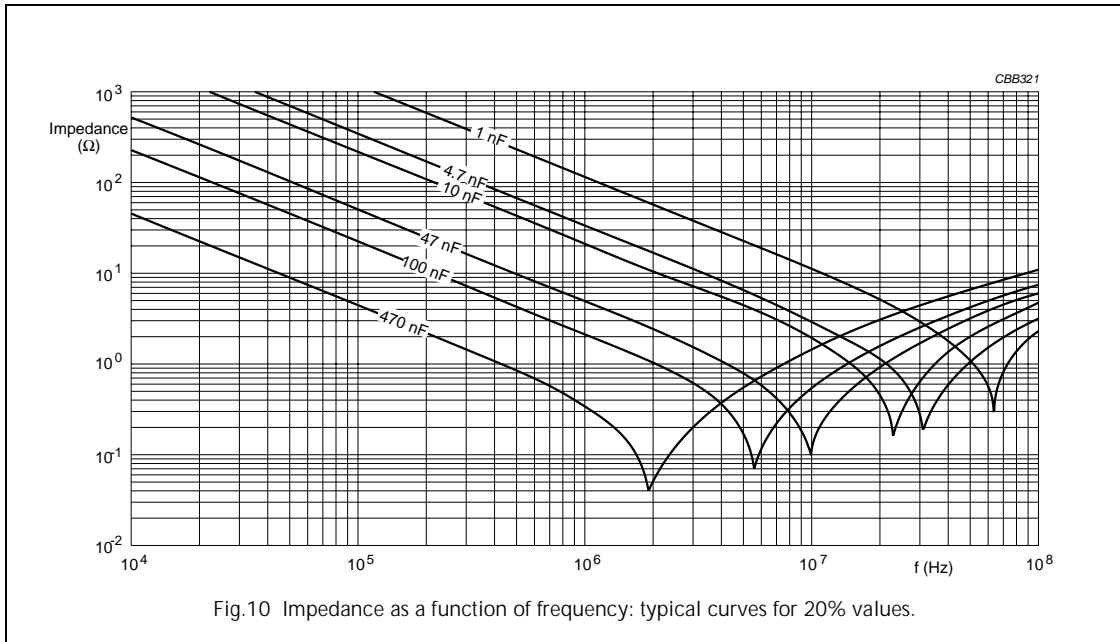

Fig.10 Impedance as a function of frequency: typical curves for 20% values.

Resonant frequency

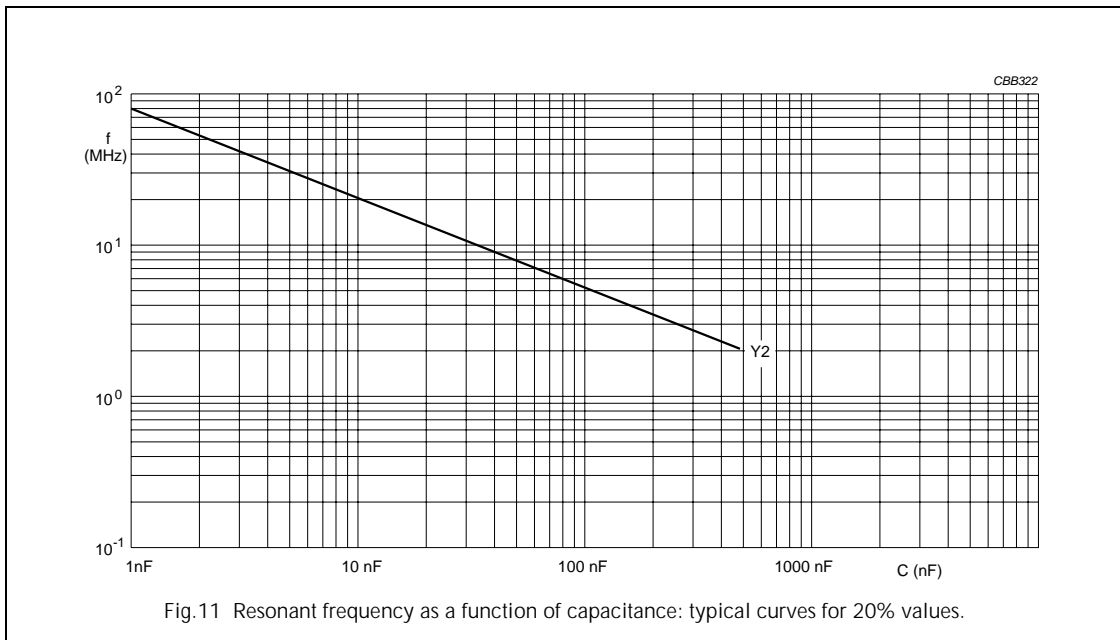
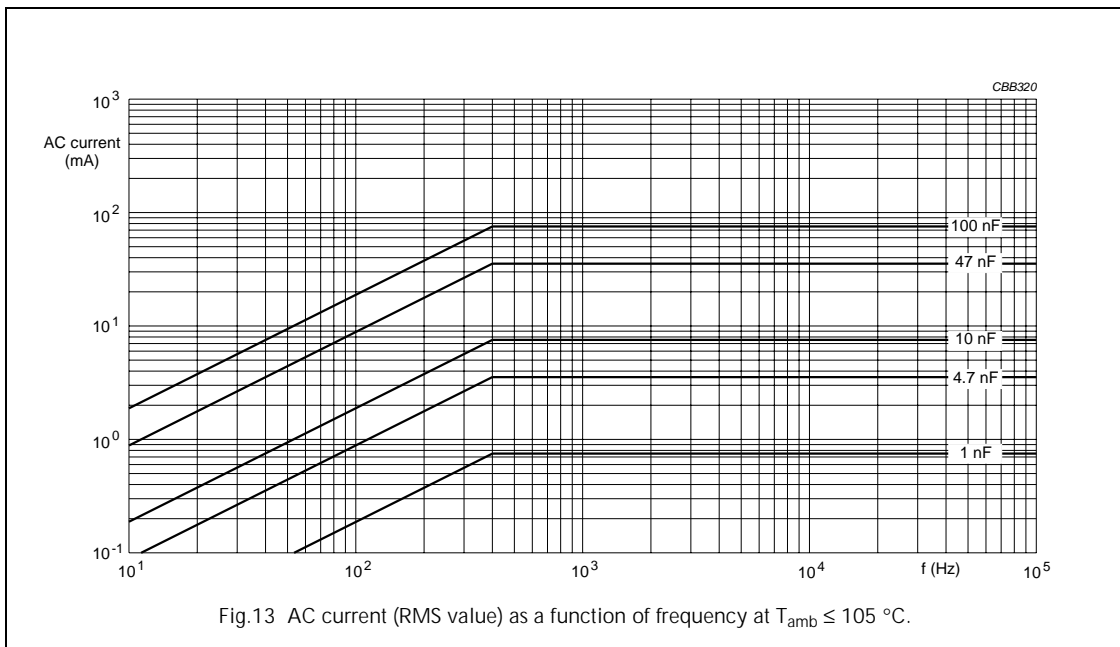
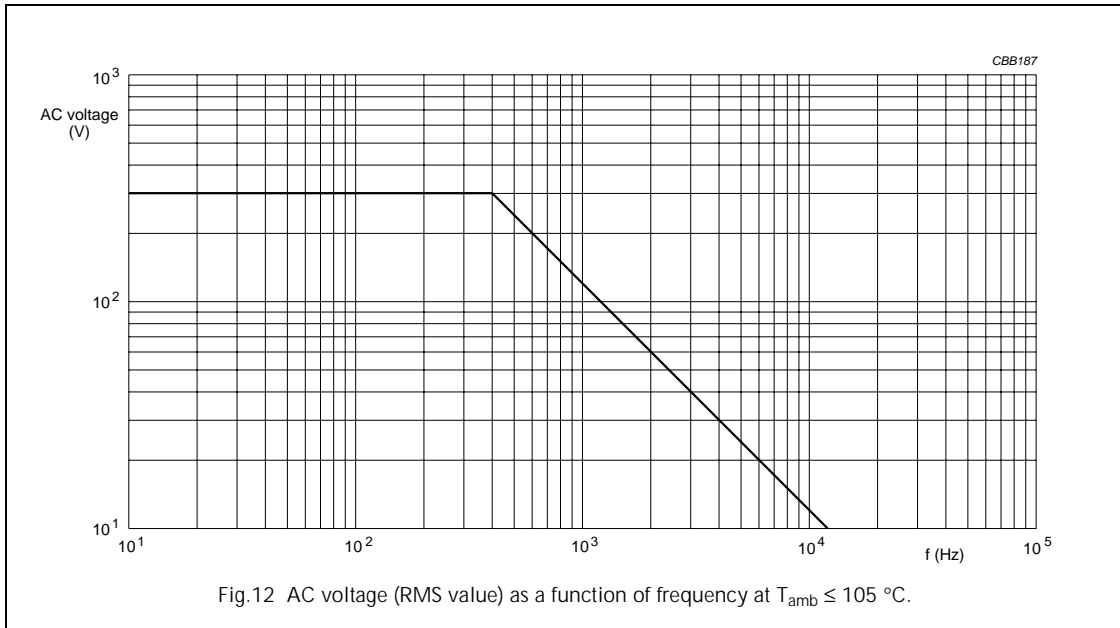

Fig.11 Resonant frequency as a function of capacitance: typical curves for 20% values.

Interference suppression film capacitors

MKP 338 6 Y2

Maximum RMS voltage and AC current (sinewave) as a function of frequency for $T_{amb} \leq 105\text{ }^{\circ}\text{C}$

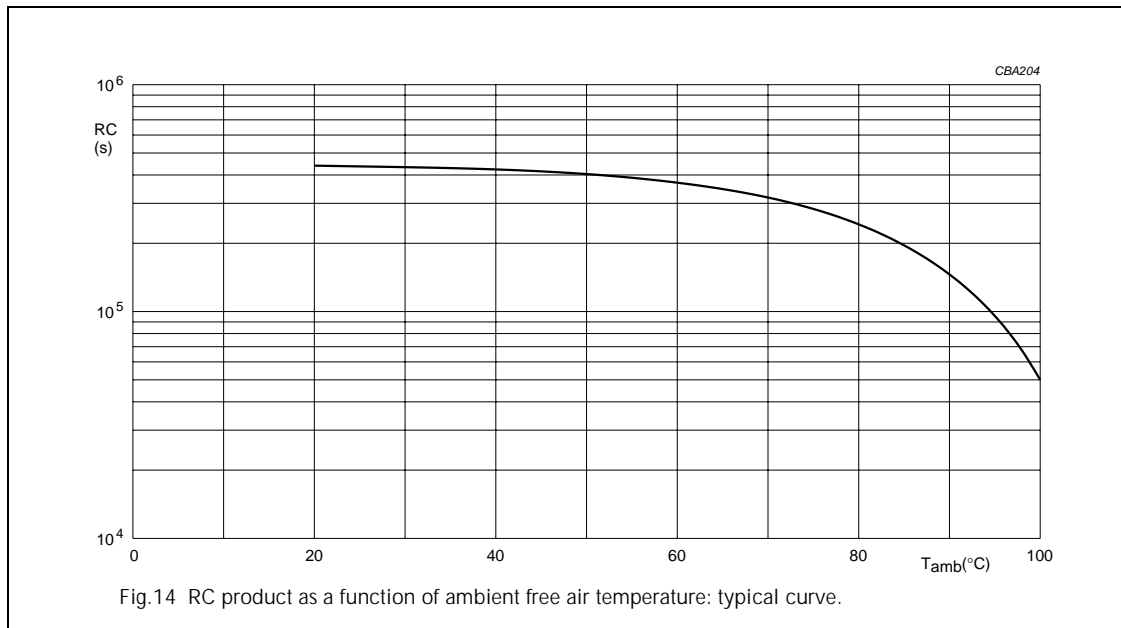

Interference suppression film capacitors**MKP 338 6 Y2****Insulation resistance****APPLICATION NOTES**

- For Y2 electromagnetic interference suppression in across the line applications (50/60 Hz) with a maximum mains voltage of 300 V (AC) ±10% instability.
- These capacitors are not intended for continuous pulse applications. For these situations, capacitors of the AC and pulse program must be used, such as: 2222 375; 2222 383 or 2222 479
- The maximum ambient temperature must not exceed 105 °C.
- Rated voltage pulse slope:
 - If the pulse voltage is lower than the rated voltage, the values of the specific reference data can be multiplied by 420 V (DC) and divided by the applied voltage.

Interference suppression film capacitors

MKP 338 6 Y2

MARKING

Product marking

The capacitors are marked (see Figs 15 to 17) with the following information:

1. Rated capacitance code in accordance with "IEC 60062"
2. Tolerance on rated capacitance; M = $\pm 20\%$; K = $\pm 10\%$; J = $\pm 5\%$
3. Rated (AC) voltage (e.g. 300 V)
4. Sub-class (e.g. Y2)
5. Manufacturer's type designation (e.g. 338 6)
6. Code for dielectric material (MKP) for capacitors with original pitch = 15, 22.5 and 27.5 mm
7. Manufacturer (BC)
8. Year and week of manufacture (e.g. 0133).

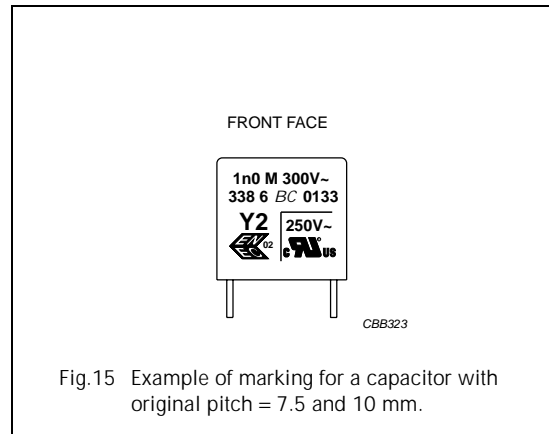

Fig. 15 Example of marking for a capacitor with original pitch = 7.5 and 10 mm.

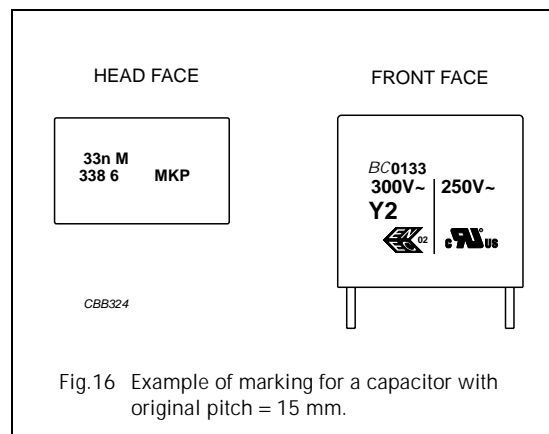

Fig. 16 Example of marking for a capacitor with original pitch = 15 mm.

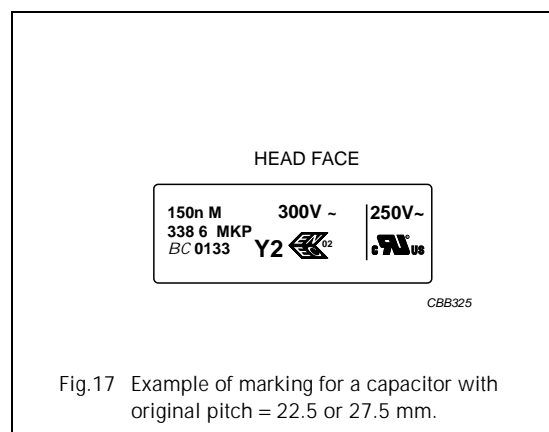

Fig. 17 Example of marking for a capacitor with original pitch = 22.5 or 27.5 mm.

Interference suppression film capacitors

MKP 338 6 Y2

Package marking

The package containing the capacitors is marked as shown Fig.18.

LINE	MARKING EXPLANATION
1	Manufacturer's name
2	Country of origin
3	Sub-family
4	Type description and sub class
5	Capacitance value, tolerance, voltage and climatic category ("IEC 60068-1")
6	Safety approvals
7	Preference origin code: A Country of origin in code: 170 (Belgium) Responsible production centre: HQ Work order: WO Wage number of final inspection (only for capacitors with original pitch = 7.5 and 10 mm)
8	Product type description
9	Quantity and production period, year and week code
10	Product code (12NC)

BCcomponents
MADE IN BELGIUM
INTERF. SUPPR. FILM CAPACITOR
MKP RADIAL POTTED TYPE
0.0047µF ±20% 300V~ 55/105/56/B
Y2
300 V~ 250 V~
WO: 12345678
ORIG A170 RPC HQ 1234
TYPE MKP 338 6
QTY 1000 DATE 0114
CODENO 2222 338 60472

Fig.18 Barcode label.

Interference suppression film capacitors

MKP 338 6 Y2

QUICK REFERENCE TEST REQUIREMENTS

TEST	PROCEDURE (quick reference)	REQUIREMENTS
Robustness of leads		
Tensile strength: "IEC 60068-2-21"	load 10 N; 10 s	no visible damage legible marking $ \Delta C/C \leq 5\%$ $\Delta \tan \delta \leq 80 \times 10^{-4}$ (C \leq 1 μ F); note 1 $\Delta \tan \delta \leq 50 \times 10^{-4}$ (C > 1 μ F); note 1
Bending: "IEC 60068-2-21"	load 5 N; 4 \times 90 °	
Resistance to soldering heat: "IEC 60068-2-20"	solder bath: 260 °C; 10 s	
Component solvent resistance	isopropyl alcohol; 23 °C; 5 minutes	
Robustness of component		
Rapid change of temperature: "IEC 60068-2-14"	5 cycles 1 cycle = 30 minutes at -55 °C and 30 minutes at 105 °C	$ \Delta C/C \leq 5\%$ $\Delta \tan \delta \leq 80 \times 10^{-4}$ (C \leq 1 μ F); note 1 $\Delta \tan \delta \leq 50 \times 10^{-4}$ (C > 1 μ F); note 1
Vibration: "IEC 60068-2-6"	10 to 55 Hz; amplitude 0.75 mm; 6 hours	
Shock: "IEC 60068-2-27"	half sinewave; 490 m/s ² ; 11 ms	
Climatic sequence		
Dry heat: "IEC 60068-2-2"	16 hours; 105 °C	$ \Delta C/C \leq 5\%$ $\Delta \tan \delta \leq 80 \times 10^{-4}$ (C \leq 1 μ F); note 1 $\Delta \tan \delta \leq 50 \times 10^{-4}$ (C > 1 μ F); note 1 $R_{ins} \geq 50\%$ of specified value
Damp heat, cyclic, test Db, first cycle: "IEC 60068-2-30"		
Cold: "IEC 60068-2-1"	2 hours; -55 °C	
Damp heat, cyclic, test Db, remaining cycles: "IEC 60068-2-30"		
Voltage proof: "IEC 60384-14"	$V_p = 2250$ V (DC); 1 minute	
Other applicable tests		
Damp heat, steady state: "IEC 60068-2-3"	56 days; 40 °C; 90 to 95% RH no load $V_p = 2250$ V (DC); 1 minute	$ \Delta C/C \leq 5\%$ $\Delta \tan \delta \leq 80 \times 10^{-4}$ (C \leq 1 μ F); note 1 $\Delta \tan \delta \leq 50 \times 10^{-4}$ (C > 1 μ F); note 1 $R_{ins} \geq 50\%$ of specified value
Endurance (AC): "IEC 60384-14"	3 \times 5 kV pulse voltage 1000 hours; 1.7 \times U_{Rac} at 105 °C; once per hour; 0.1 s; 1000 V (RMS) via resistor of 47 Ω ; $V_p = 2250$ V (DC); 1 minute	

Interference suppression film capacitors**MKP 338 6 Y2**

TEST	PROCEDURE (quick reference)	REQUIREMENTS
Charge and discharge: "IEC 60384-14"	10000 cycles; 5 ms; 1.5 × dV/dt	$ \Delta C/C \leq 10\%$ $\Delta \tan \delta \leq 80 \times 10^{-4}$ (C ≤ 1 μF); note 1 $\Delta \tan \delta \leq 50 \times 10^{-4}$ (C > 1 μF); note 1 $R_{ins} \geq 50\%$ of specified value
Passive flammability: "IEC 60384-14"	class B	no burning
Active flammability: "IEC 60384-14"	20 × 5 kV discharge	no burning
Heat storage: "IEC 60384-14"	1000 hours; 105 °C	$ \Delta C/C \leq 5\%$ $\Delta \tan \delta \leq 80 \times 10^{-4}$ (C ≤ 1 μF); note 1 $\Delta \tan \delta \leq 50 \times 10^{-4}$ (C > 1 μF); note 1
Resistance to soldering heat with preheating: "IEC 60384-14"	preheating: 105 °C; solder bath: 260 °C; 10 s	$ \Delta C/C \leq 5\%$ $\Delta \tan \delta \leq 80 \times 10^{-4}$ (C ≤ 1 μF); note 1 $\Delta \tan \delta \leq 50 \times 10^{-4}$ (C > 1 μF); note 1
Active flammability test	voltage proof up to 2 × peak impulse voltage of 4.13 or until breakdown (100 V/sec, current limited 2mA) failed capacitors connected to a 250 V (AC) power supply during 5 minutes.	no burning

Note

1. Measuring frequency 10 kHz for C ≤ 1 μF and 1 kHz for C > 1 μF.